

Genovations® Stair Railing Installation Instructions- 36" Square, Deluxe Square, & Colonial

T O O L S	Measuring Tape
	Pencil or Marker
	Handsaw
	Hacksaw
	Drill with 1/8" and 5/32" drill bits
	Screwdriver
	Level
7/16" Socket Wrench	
	Rope

⚠ WARNING

- To avoid serious eye and hand injuries or blindness, always wear safety glasses and gloves.

C O M P O N E N T S					⚠ WARNING
			6 ft. Deluxe Square or Colonial	8 ft. Deluxe Square or Colonial	
	6 ft. Square	8 ft. Square			<ul style="list-style-type: none"> • Stairways without railings offer no protection from falling. • Falling from a stairway could result in serious injury. • Stair rails and a handrail are required on stairs with a total rise exceeding thirty inches (30').
	2	2	2	2	2" x 4" Vinyl Rails
	-	-	1	1	Colonial Rail Cover
	1	1	1	1	Aluminum P-Channel (Top Rail Insert)
	1	1	1	1	Aluminum Step-Channel (Bottom Rail Insert)
	12	16	12	16	Balusters
	4	4	4	4	Mounting Brackets
	4	4	4	4	Mounting Bracket Covers
4	4	4	4	Stair Rail Adapters	
4	4	4	4	1/4" x 3" Lag Screws (attach Adapters to Posts)	
4	4	4	4	1/4" x 4" Lag Screws (attach Adapters to Posts)	
8	8	8	8	#10 x 3/4" Pan Head Sheet Metal Screws (attach Aluminum Inserts to Brackets)	

Parts Needed To Assemble Rail Section:

- 4" x 4" x 38" Post Cover
- 4" x 4" x 50" Stair Rail Post Cover
- 4" x 4" Treated Wood Post
- 4" Post Trim Base
- Genova Vinyl Sealant
- Post Tops - Gothic, Ball, Bevel, or New England

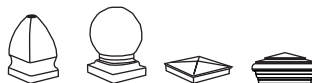

Optional Parts Available:

- Bracket Kits to make two shorter sections from one section
- Round Handrail Cover
- Handrail Bracket Kit
- Universal Rail Adapter Kit

GENERAL INFORMATION

Before starting this project, be sure to consult your local building department for codes and regulations for guardrail installations. Your new railings have been evaluated and quality tested to ensure that they comply with the International Residential Code (IRC) requirements and AC-174 entitled, "Acceptance Criteria for Deck Board Span Ratings and Guardrail Systems" (Guards and Handrails), and have been assigned ICC Evaluation Service Report # ESR-1904. This product is not to be used for commercial installations. This product is not to be used in access ramps for the disabled. This product is not to be used in marine fueling stations. This product is to be used only in exterior applications for residential construction.

INSTALLATION INSTRUCTIONS:

1. Posts

- Install treated wood posts in accordance with building code requirements. See Sizing Chart for Post locations.
- Cut upper wood posts to 36" above the deck surface. Cut the lower wood posts to 41" above the stair tread.
- Slide the Genova 4" x 38" Post Cover over the upper posts and a Genova 4" x 50" Post Cover over the lower posts. Cut the 4" x 50" Post Cover to 42" if it sits on the stair tread.
- Install shims between the wood post and the Post Cover on all four sides. Strips of plywood or a solid weather resistant material is recommended as shim stock.

6 ft. Section
Figure A.1

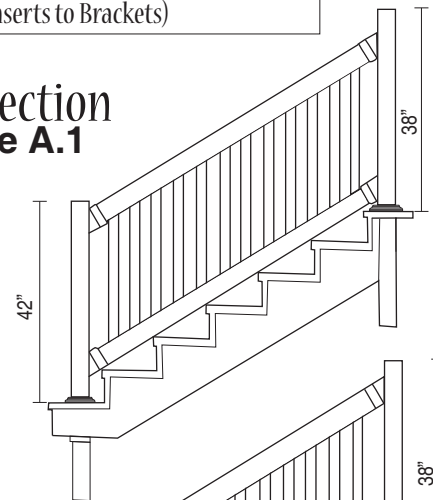

8 ft. Section
Figure A.2

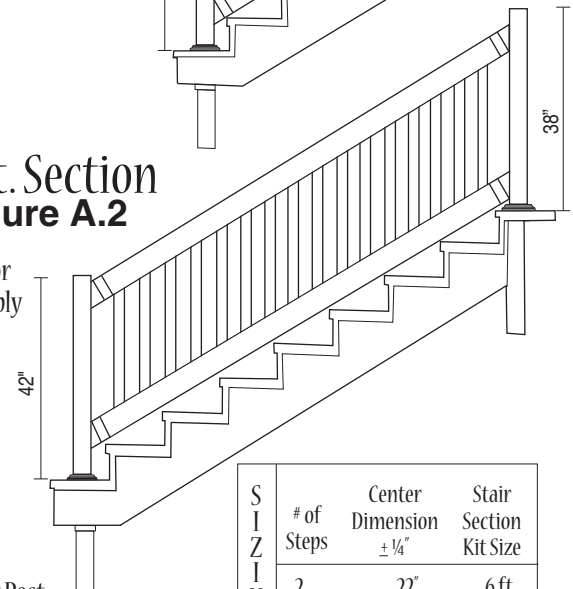

S I Z I N G	# of Steps	Center Dimension ± 1/4"	Stair Section Kit Size
3	31-3/8"	6 ft.	
4	45-3/8"	6 ft.	
5	54-3/4"	6 ft.	
6	64-1/8"	6 ft.	
7	79-1/8"	8 ft.	
8	83-7/8"	8 ft.	
Based upon a 7"x11" step system			

E. Slide the 4" Post Trim Base over the Post Cover and push it down so it is flush with the deck.

2. Mounting Brackets

- To determine the location of the Brackets lay a straight edge across the nose of the stairs and against the side of the Post Covers and mark with a pencil. (Figure B.1) Transfer the pencil marks to the side of the top post facing down the stairs and to the side of the bottom post facing up the stairs.
- Mark the upper and lower Stair Rail Posts at $\frac{1}{4}$ " and at 29-9/16" above this mark (Figure B.2). These marks locate the bottom edge of the Stair Rail Adapters. Center the Stair Rail Adapters with the webbed side against the post and pre-drill $\frac{1}{8}$ " holes for the mounting screws. **Deluxe Square and Colonial Sections Only**- The 2 square adapters go on the bottom of the Post. The 'A' Colonial Adapter attaches to the top of the upper Post and the 'B' Colonial Adapter attaches to the top of the lower Post.
- Mate the Mounting Brackets to the Stair Rail Adapters using the 2 locating pins on the flat side of the Adapters. Attach the Mounting Bracket and Stair Rail Adapter at the appropriate post locations with one 3" and one 4" Lag Screw (Figure C).

Figure B.1

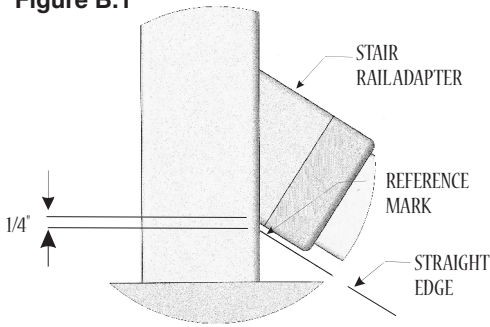

Figure B.2

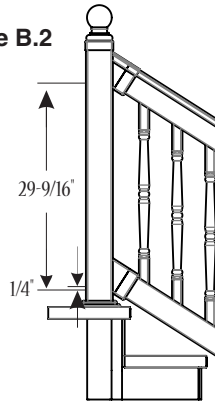
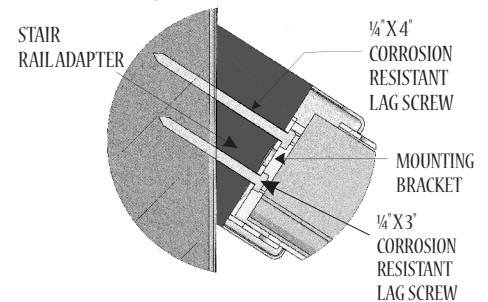

Figure C



3. Rails

- Measure the distance between the "INSERT TO HERE" windows in the top Mounting Brackets (hook the measuring tape onto one window and measure the distance to the opposing window). Cut, if necessary, the Aluminum P-Channel Rail Inserts to this length.
- Measure the distance between the "INSERT TO HERE" window in the bottom Mounting Brackets. Cut (if necessary) the Aluminum Step-Channel Insert to this length.
- Subtract 1-3/8" from the (cut) Aluminum Rail Insert lengths, and cut the corresponding 2" x 4" Vinyl Rails to that length. When cutting the Rails, observe the "Top Rail-Cut This End Only" sticker and the "Bottom Rail Cut This End Only" sticker. These stickers must both be oriented toward the top of the stairs.
- Deluxe Square and Colonial Sections Only**- Cut the Colonial Rail Cover to the same length as the top Vinyl Rail. Apply a generous bead of Genova Vinyl Sealant down the center and on the sides of the trough portion of the Colonial Rail Cover. Insert the 2" x 4" Vinyl Rail in the trough so the Baluster holes are visible (opposite and away from the Colonial Rail Cover.) Square up the ends and clamp the pieces together. Wipe off any excess Sealant. Allow the Sealant to set approximately 30 minutes before continuing.

4. Section Assembly

- Lay Vinyl Rails on a clean flat surface, with the Baluster holes facing each other. Insert the Aluminum P-Channel Rail Insert into the top Vinyl Rail. The long leg of the Aluminum P-Channel Rail Insert must point down and toward the holes. (Figure D)
- Insert the Aluminum Step-Channel into the bottom Vinyl Rail. The long leg of the Aluminum Step-Channel must point up and toward the holes. The long leg of both Aluminum Rail Inserts must be on the same side of the holes.
- With the bottom Rail lying on its side, insert the Balusters into the routed holes.
- While still lying on its side, insert the Balusters into the Top Rail, working from one end to the other.
- Cinch the rail assembly together using a piece of rope. This will hold the entire assembly together while moving it into place.
- Slide the Mounting Bracket Covers over the ends of the Vinyl Rails with the notched ends on the bottom and facing toward the Balusters. (To accommodate a close Baluster, rotate the Bottom Bracket Cover, so the "notched" side faces up. If necessary, split the cover and glue together after installation.)
- Slide the assembled rail section into the Mounting Brackets with the long legs of the Aluminum Rail Inserts facing the stairs. Center the assembly by aligning the Aluminum Rail Inserts with the "INSERT TO HERE" windows in the Brackets. The Aluminum Rail Inserts should extend 1/16" beyond the Vinyl Rail at each end.
- Locate the Scribe Lines in the center of the elongated holes on the Mounting Brackets. Drill 5/32" diameter holes through the long legs of both Aluminum Rail Inserts at these locations (two per bracket). (Figure E)
- Secure the Aluminum Rail Inserts to the Mounting Brackets, using #10 x 3/4" Pan Head Sheet Metal Screws in each of the holes. **CAUTION: Do not over tighten the screws.**
- Slide the Mounting Bracket Covers over the Mounting Brackets until they snap into place. Remove the rope.
- Apply Genova Vinyl Sealant to the inside flat surfaces of the Post Tops and attach them to the Post Covers.

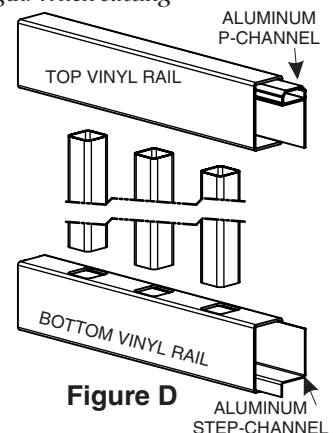

Figure D

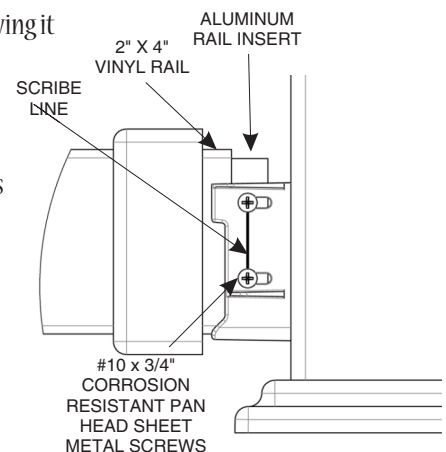

Figure E